

EN

# RENO 100<sup>®</sup>

PE100

Polyethylene piping systems manufactured from PE100 (MRS 10), black in colour with blue identification stripes and blue in colour, intended for the supply of drinking water and raw water prior to treatment, compliant with the requirements of the international standards EN 12201, ISO 4427 and EN 1622 and the national regulations for drinking water.

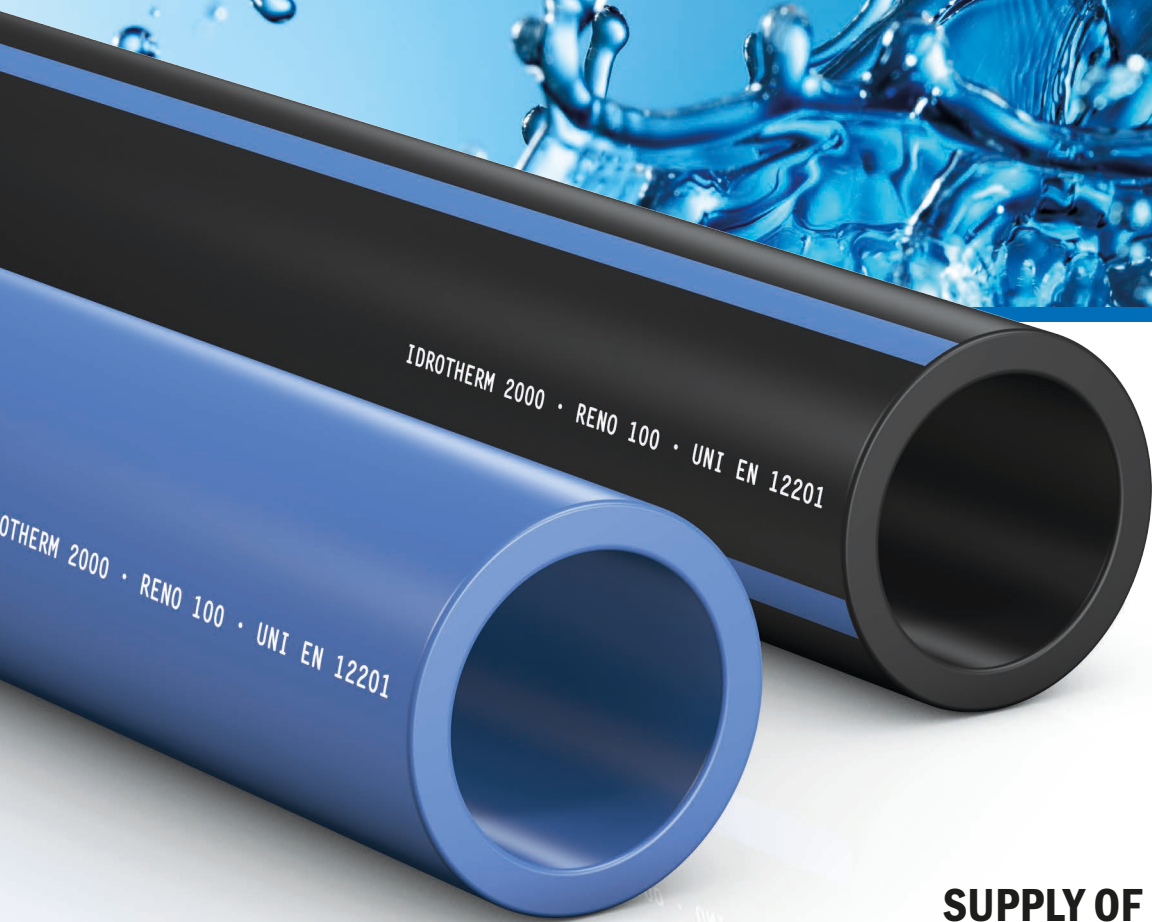

**SUPPLY OF DRINKING WATER**

 **IDROTHERM<sup>®</sup>**  
2000



### Design considerations

The design of a piping network based on RENO 100 is focused on the determination of the pipe diameter for a specific layout once parameters as flow, total length, piezometric height and roughness are completely defined.

The criteria for dimensioning a pipeline, as described in standards, must be able to fulfil the maximum required flow, balancing the water supply according to the demand and evaluating the velocity of the fluid in the pipe, the roughness coefficient of the internal surface and the pressure difference between the ends of the piping system.

The distributed pressure drop may be estimated through an abacus which links the flow (Q) and the velocity (V) of the fluid to the internal diameter (d) of the pipeline. It is generally advisable to operate with a fluid velocity in the range 0.5-2.5 m/s in order to avoid overpressure and stagnation. On the other hand, the pressure drops due to the flow through fittings and valves have to be estimated according to their specific type as described in standards.

Pipelines based on RENO 100 are also suitable for fire-fighting networks provided national rules are taken into account for this specific use.

### Installation in trenches

According to the standard ENV 1046 the width of the trench at the springline of the pipe must not be greater than necessary to provide adequate room for jointing the pipe in the trench and compacting the pipe zone backfill at the haunches (typical values are  $b_s = 200$  mm for  $DN \leq 300$ ,  $b_s = 300$  mm for  $300 \leq DN \leq 900$  and  $b_s = 400$  mm for  $900 \leq DN \leq 1200$ ).

When determining the trench depth, allowance for a suitable bedding should be incorporated. In general, care should be taken that the depth of cover above the crown of the pipe for pipes passing under traffic areas should usually be a minimum of 600 mm and to prevent the conveyed fluids from being affected by frost. The surface at the trench grade shall be continuous, uniform and free of particles greater than 15 mm for  $DN < 100$ , 20 mm for  $100 \leq DN < 300$ , 30 mm for  $300 \leq DN < 600$  and 40 mm for  $DN \geq 600$ . To provide a uniform support for the pipe the bedding layer should generally have a thickness of 100 - 150 mm and be not less than 50 mm and the material shall be granular such as gravel, sand or crushed rock.

The backfill above the pipe zone should be placed by spreading in approximately uniform layers and compacted according to the various types of equipment and backfill materials.

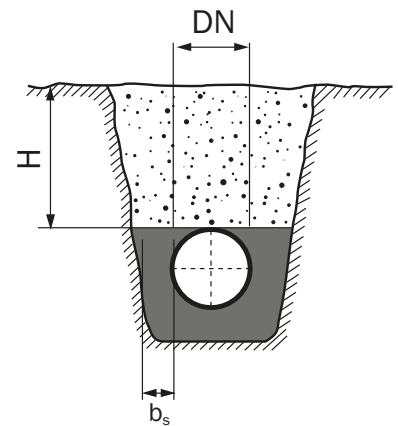

### Bending

RENO 100 pipes have a high degree of flexibility and can follow the undulations of the ground without bends, provided the radius of curvature is higher than a limit value which depends on the SDR. The minimum bending radius at 20 °C is defined as in the side table.

SDR	Radius of curvature
7,4 - 17	$\geq 25$ DN
21 - 26	$\geq 35$ DN

### Chemical resistance

In the event it is necessary to evaluate the chemical resistance of RENO 100 for specific installations, the pipes shall be classified in accordance with international guidelines (i.e. standard ISO/TR 10358). For a few chemical substances used at 20 °C the resistance is classified as in the side table.

Chemical	Resistance
Ethyl alcohol (40%)	S
Chlorine (sol.)	L
Sodium chloride (2%)	S
Chlorine dioxide	NS

- S = satisfactory resistance
- L = limited resistance
- NS = not satisfactory resistance

## Joining

A piping system based on RENO 100 can be jointed through butt-fusion welding, electrofusion or mechanical compression joints. The choice of the most adequate jointing technique can affect the reliability and the long term behaviour of the pipe network. The range of pipe diameters intended to be assembled with different methods is summarised in the following table.

Joining method	Range of DN
Butt-fusion	DN ≥ 63 mm
Electrofusion	DN ≥ 20 mm

## Testing

A piping network for water supply has to be subjected to a hydrostatic pressure test to ensure the integrity of pipes, couplings, fittings and other components, such as anchor blocks, following the instructions given in standards such as EN 805.

Testing should be done after the backfilling of the trench leaving the joints uncovered. Filling of the piping network with water must be done slowly to avoid water hammers, air must be expelled and finally the venting devices must be closed.

The system test pressure (STP) must be calculated according to the maximum design pressure (MDP) as follows:

- for calculated water hammer:

$$\text{STP} = \text{MDP}_c + 100 \text{ kPa}$$

- without calculated water hammer:

$$\text{STP} = \text{MDP}_a \times 1,5 \text{ or } \text{MDP}_a + 500 \text{ kPa}$$

(the lower of the two values)

## Operation

When a piping system based on RENO 100 is to be operated at a constant temperature higher than 20 °C, up to 40 °C, a pressure reduction coefficient as given in the following table applies (extract from EN 12201-1).

Temp. °C	PN 6	PN 10	PN 12,5	PN 16	PN 20	PN 25
≤ 20	6	10	12,5	16	20	25
30	5,2	8,7	10,8	13,9	17,2	21,7
40	4,4	7,4	9,2	11,8	14,7	18,5

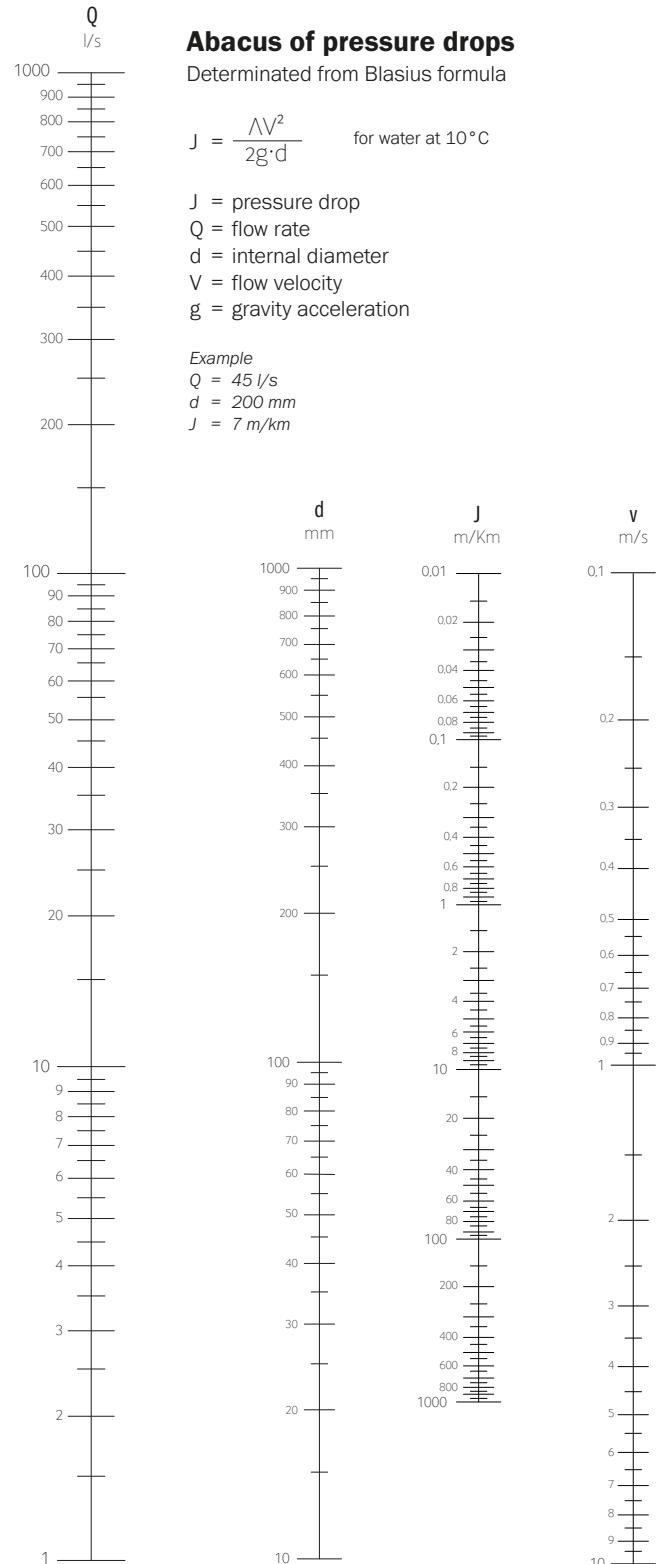



# RENO 100<sup>®</sup>

## Supply of drinking water



DN mm	PN 6 SDR 26		PN 10 SDR 17		PN 12,5 SDR 13,6		PN 16 SDR 11		PN 20 SDR 9		PN 25 SDR 7,4	
	e <sub>n</sub> mm	DI mm	e <sub>n</sub> mm	DI mm	e <sub>n</sub> mm	DI mm	e <sub>n</sub> mm	DI mm	e <sub>n</sub> mm	DI mm	e <sub>n</sub> mm	DI mm
20	-	-	2,0•	16,0	2,0•	16,0	2,0	16,0	2,3	15,4	3,0	14,0
25	-	-	2,0•	21,0	2,0	21,0	2,3	20,4	3,0	19,0	3,5	18,0
32	-	-	2,0	28,0	2,4	27,2	3,0	26,0	3,6	24,8	4,4	23,2
40	-	-	2,4	35,2	3,0	34,0	3,7	32,6	4,5	31,0	5,5	29,0
50	-	-	3,0	44,0	3,7	42,6	4,6	40,8	5,6	38,8	6,9	36,2
63	-	-	3,8	55,4	4,7	53,6	5,8	51,4	7,1	48,8	8,6	45,8
75	-	-	4,5	66,0	5,6	63,8	6,8	61,4	8,4	58,2	10,3	54,4
90	-	-	5,4	79,2	6,7	76,6	8,2	73,6	10,1	69,8	12,3	65,4
110	-	-	6,6	96,8	8,1	93,8	10,0	90,0	12,3	85,4	15,1	79,8
125	-	-	7,4	110,2	9,2	106,6	11,4	102,2	14,0	97,0	17,1	90,8
140	-	-	8,3	123,4	10,3	119,4	12,7	114,6	15,7	108,6	19,2	101,6
160	6,2	147,6	9,5	141,0	11,8	136,4	14,6	130,8	17,9	124,2	21,9	116,2
180	6,9	166,2	10,7	158,6	13,3	153,4	16,4	147,2	20,1	139,8	24,6	130,8
200	7,7	184,6	11,9	176,2	14,7	170,6	18,2	163,6	22,4	155,2	27,4	145,2
225	8,6	207,8	13,4	198,2	16,6	191,8	20,5	184,0	25,2	174,6	30,8	163,4
250	9,6	230,8	14,8	220,4	18,4	213,2	22,7	204,6	27,9	194,2	34,2	181,6
280	10,7	258,6	16,6	246,8	20,6	238,8	25,4	229,2	31,3	217,4	38,3	203,4
315	12,1	290,8	18,7	277,6	23,2	268,6	28,6	257,8	35,2	244,6	43,1	228,8
355	13,6	327,8	21,1	312,8	26,1	302,8	32,2	290,6	39,7	275,6	48,5	258,0
400	15,3	369,4	23,7	352,6	29,4	341,2	36,3	327,4	44,7	310,6	54,7	290,6
450	17,2	415,6	26,7	396,6	33,1	383,8	40,9	368,2	50,3	349,4	61,5	327,0
500	19,1	461,8	29,7	440,6	36,8	426,4	45,4	409,2	55,8	388,4	-	-
560	21,4	517,2	33,2	493,6	41,2	477,6	50,8	458,4	62,5	435,0	-	-
630	24,1	581,8	37,4	555,2	46,3	537,4	57,2	515,6	70,3	489,4	-	-
710	27,2	655,6	42,1	625,8	52,2	605,6	64,5	581,0	79,3	551,4	-	-
800	30,6	738,8	47,4	705,2	58,8	682,4	72,6	654,8	89,3	621,4	-	-
900	34,4	831,2	53,3	793,4	66,1	767,8	81,7	736,6	-	-	-	-
1000	38,2	923,6	59,3	881,4	73,5	853,0	90,8	818,4	-	-	-	-
1200	45,9	1108,2	-	-	-	-	-	-	-	-	-	-

• Thickness rounded to lower SDR      DN = nominal outside diameter      DI = inner diameter      e<sub>n</sub> = nominal thickness



The range of certified products can be checked on [www.idrotherm2000.com](http://www.idrotherm2000.com) and on the websites of the certification bodies



Via Pio La Torre, 21 - 55032 Castelnuovo Garfagnana (Lu) Italy  
Tel. +39 0583 65496 - Fax +39 0583 62033  
[www.idrotherm2000.com](http://www.idrotherm2000.com) - [info@idrotherm2000.com](mailto:info@idrotherm2000.com)

**TECHNICAL SERVICE**  
**+39 0583 65496**  
[info@idrotherm2000.com](mailto:info@idrotherm2000.com)